



INSTALLATION INSTRUCTIONS – ALUMINUM ALLOY FUEL DOOR

APPLICATION:

99-03 MUSTANG
97 & UP FORD F-150 TRUCK (EXCLUDES SUPERCREW)
99 & UP FORD F-250/350
97 & UP FORD EXPEDITION
2000 & UP FORD EXCURSION

PART NUMBER: 10-1066-10

KIT CONTENTS



M4 Nut. For use on
F-Series Trucks
Only.

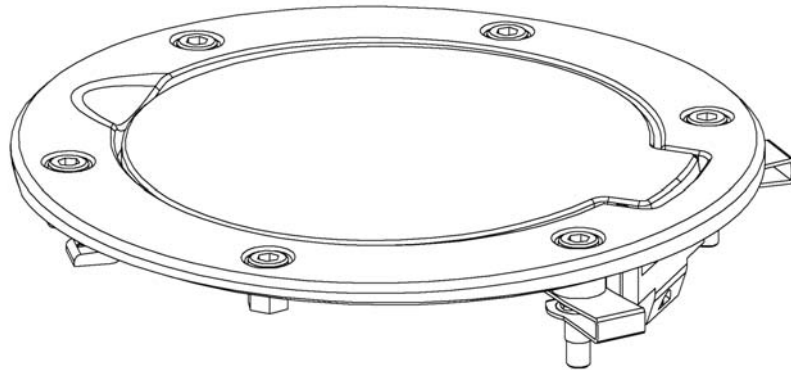

TOOLS REQUIRED: T20 Torx Wrench

Removing Stock Fuel Door: After opening the stock fuel door, remove the two bolts (Torx T-20) mounting the fuel door hinge. After removing these two bolts, the fuel door hinge will have to be slightly closed before removing. Remove the two rubber stops.

Applying mounting nuts to the automobile's body:

Mustang: Apply the U-style threaded nuts on the plastic panel that lies under and tucked against the sheet metal. The u-style nuts will be lined up behind the mounting holes for the stock fuel door hinge. After the U-style nuts are in place, remove the rubber stops from their mounting screws and reapply the screws to the car. Do not reapply the two bolts that mounted the stock fuel door hinge.

F-Series Trucks: U-style threaded nuts will be applied after fuel door is positioned.

ALLOY FUEL DOOR
ASSEMBLY FOR
MUSTANG

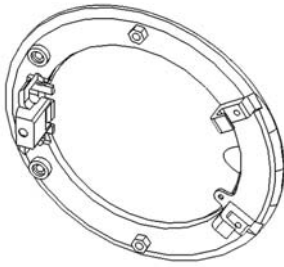

Nylon Clips to stay
on as in received
condition. Discard
M4 Nut.

ALLOY FUEL DOOR
ASSEMBLY FOR
F-150 SERIES TRUCK

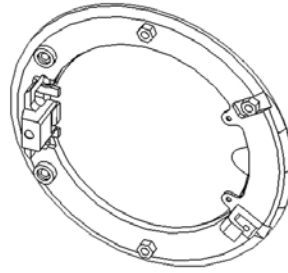

Remove Upper
Nylon Clip. Replace
with supplied M4
Nut.

ALLOY FUEL DOOR
ASSEMBLY FOR
F-250 SERIES TRUCK

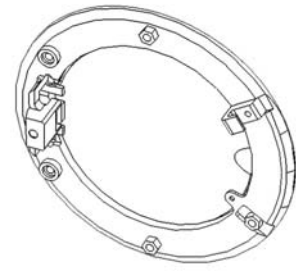

Remove Lower
Nylon Clip. Replace
with supplied M4
Nut.

Affixing Fuel Door: To mount the fuel door, angle the fuel door into position with the mounting clips hooking onto the sheet metal of the fuel door cavity. After clipped onto the sheet metal, the pivot end of the fuel door should drop into place. With the mounting bolts lined up with mounting holes, the mounting bolts should be threaded and tightened into u-style threaded nuts.

For F-Series trucks, the nuts are to be held in place behind the mounting holes.

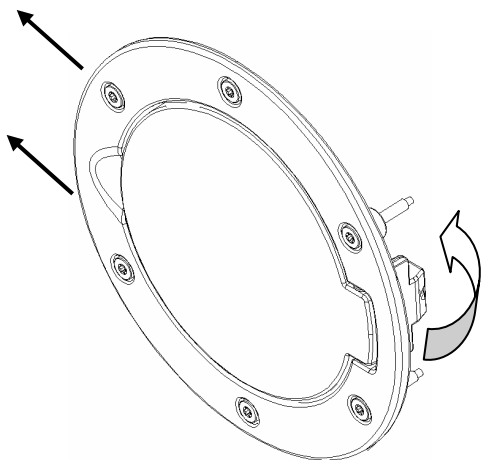

Mustang Installation

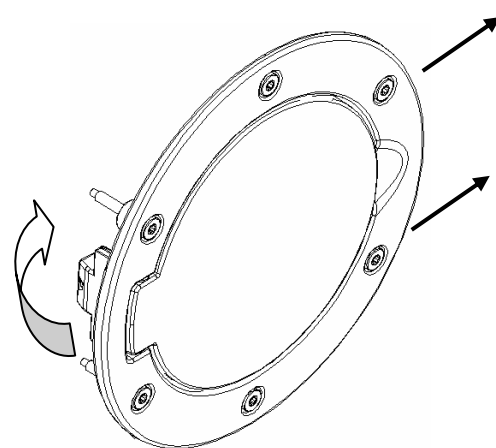

F-Series Installation